

Sample Protection Philosophy for Non-injecting Inverter-based Sources

This document is not an approval for connection. It is intended as a guide for proponents regarding the kinds of protections needed. This document is a summary of a sample protection philosophy for non-injecting, inverter-based (NI/I) connections including storage, solar, and wind. It provides guidance to a DER proponent on good utility practice as it relates to protection requirements of non-injecting, inverter-based (NI/I) DERs.

A proponent will need to submit detailed protection settings before the utility has completed the impact assessment of the connection application submitted.

The protection system of the connection will be designed to:

- Detect internal faults with the generator facility, downstream of the Point of Common Coupling (PCC), and automatically disconnect the NI/I source
- Detect external faults on the utility feeder and automatically disconnect the NI/I source
- Detect islanding conditions and disconnect the NI/I source
- Detect export of power from the NI/I source to the utility feeder and automatically disconnect the NI/I source

Internal Faults Within the Generator Facility

The following protections are in place to protect against internal faults resulting from the NI/I source:

- **Multi-Function Relay**- A multi-function relay is installed between the generator and the main breaker to monitor internal faults resulting from the NI/I source. The 52 Circuit Breaker will trip if it detects the following:
 - o 25 - Synchronization Check
 - o 27 - Undervoltage
 - o 50/51- Overcurrent
 - o 59 - Overvoltage
 - o 67 - Directional
 - o 81O/U - Under and Over Frequency
 - o ID -Active Anti-Islanding
- **Inverter Breakers** - Each inverter is equipped with an AC breaker at the output of the inverter providing additional overcurrent protection
- **Facility Overcurrent Protection** - All circuits within the facility are protected from both phase-to-phase and phase-to-ground faults by appropriate overcurrent protection devices. Fuses are sized to clear under fault conditions within the generator facility.

External Phase and Ground Faults in the Distribution System

The following protections are in place to protect against external faults resulting from the utility feeder:

- **Multi-Function Relay** - A multi-function relay will be installed between the generator and the main breaker to monitor faults from the utility feeder. The 52 Circuit Breaker will trip under the following faults:
 - o 27 - Undervoltage
 - o 32R- Reverse Power
 - o 50/51- Overcurrent
 - o 59 - Overvoltage
 - o 81O/U - Under and Over Frequency
 - o 67 - Directional
- **Inverter Protection:** The inverters proposed for this project are certified to UL 1741, IEEE 1547, CSA C22.2 107.1-01 standards and will behave accordingly.

Anti-Islanding

- The Energy Resource Facility will operate in a grid following mode and will not operate islanded.
- **Anti-Islanding Inverters** -The NI/I source inverters contain both passive and active anti- islanding protection as required by IEEE 1547 and UL1741 SA. If the utility normal power supply is interrupted, the inverters detect the loss of power and disconnect.

Reverse Power

- **Reverse Power Protection** - In addition to the multi-function relay at the utility supply monitoring reverse power (32R), the load is continually monitored to ensure the NI/I source discharge is below the consumption of the facility. This additionally protects against power injection to the utility grid.

Directional Overcurrent

- **Directional overcurrent protection** - Directional overcurrent relays are normally used on incoming line circuit breakers on buses which have two or more sources. They are connected to trip an incoming line breaker for fault current flow back into the source, so that a fault on one source is not fed by the other sources.

Special Comment Regarding Inverter Based Generation

The inverters specified for this project have a limited fault current contribution.

- Because inverters are current-limited devices, unlike rotating generators, the fault current is very close to the maximum output current, limiting the fault current in the system to 120% -140% of FLA.

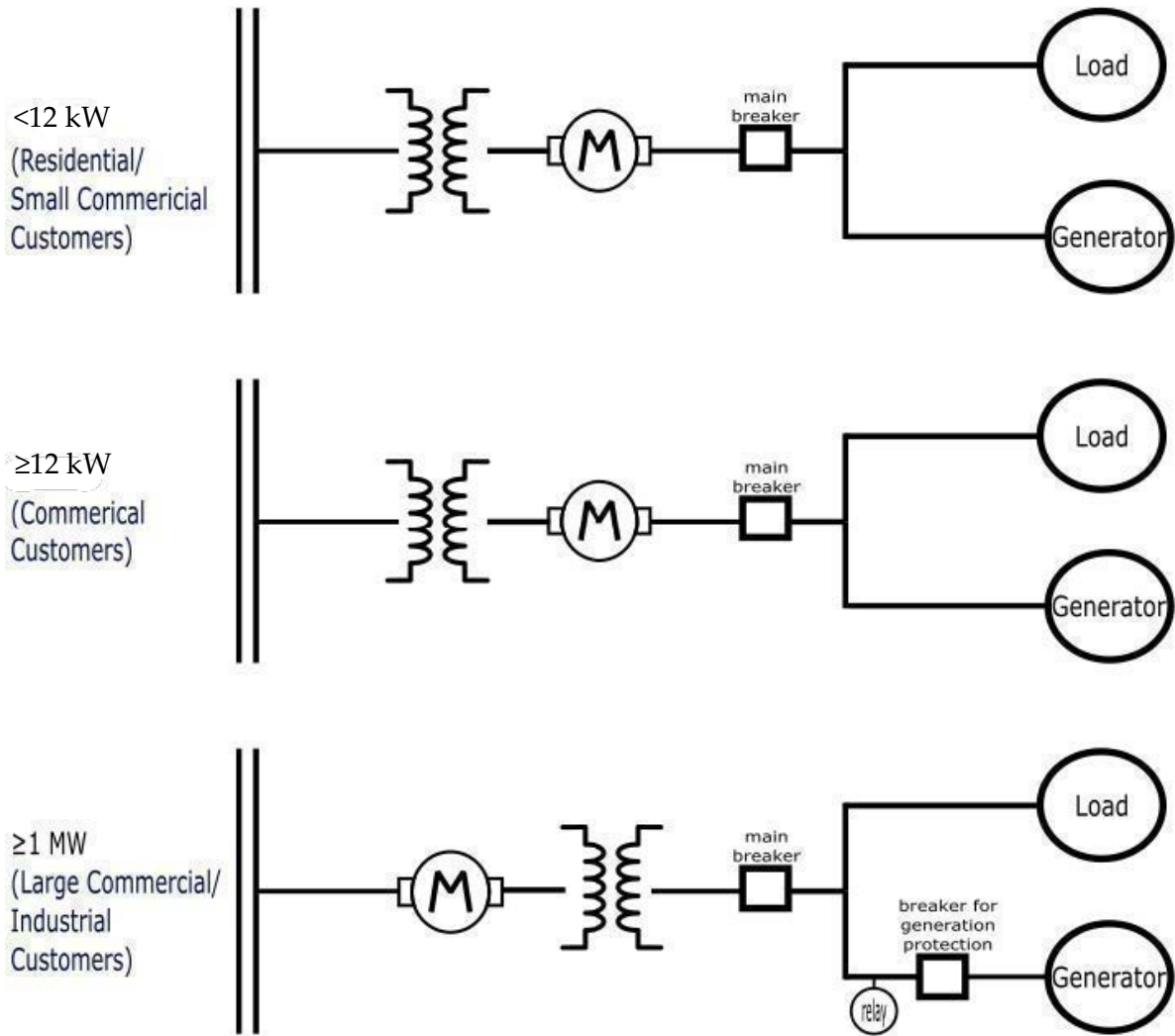

Figure 1: Typical DER Configurations

Table 1: Protection Summary Matrix

Description	IEEE Device	Internal Faults	External Faults	Anti-Islanding	Reverse Power
Over-Voltage	59	X	X	X	
Under-Voltage	27	X	X	X	
Over-Frequency	81O	X	X	X	
Under-Frequency	81U	X	X	X	
Instantaneous Over-Current Phase	50	X	X		
Timed Over-Current Phase	51	X	X		
Reverse Power	32R			X	X
Directional	67	X	X		
Active Anti-Islanding	IEEE 1547			X	

Table 2: Protection Elements

Protection Element Function	Device#	Feeder Protection Relay/Shunt Trip	IEEE 1741 SA Inverter
Over-Voltage	59	X	Y
Under-Voltage	27	X	Y
Over-Frequency	81O	X	Y
Under-Frequency	81U	X	Y
Synchronization Check	25	X	Y
Reverse Power	32R	X	
Overcurrent	50/51	X	Y
Directional	67	X	
Active Anti-islanding	ID		X

X=Primary

Y = Secondary